



PST150-11

PST150-C

MANUAL



HUZHOU DAIXI ZHENHUA TECHNOLOGY TRADE CO., Ltd.

PACIFIC RIM INT'L WEST INC.

PREFACE

To my dear customers:

We'd like express our gratitude for your choosing ZHENGHUA motorcycles.

ZHENGHUA motorcycles are sold overseas for its reasonable design, advanced technique and beautiful appearance. The quality of our products enjoys good reputation among new and old customers.

As an ideal foot-substitute and transport tool, ZHENGHUA motorcycles will offer you more convenience to your work and bring more pleasure to your life.

The manual contains the right and simple way to use and maintain the motorcycles. Please read carefully before using it. It is very helpful for your using and maintenance. In order to make your motorcycle work in good condition, please use the initial fitting of ZHENGHUA factory. If you have any question and difficulty in the process of using our motorcycles, please contact us in time. We would supply you with high-efficiency and quality service.

Your sincere suggestion for ZHENGHUA motorcycles are warmly welcomed.

TABLE OF CONTENTS

CONSUMER INSTRUCTION.....	3	TOOLS.....	23
PARTS LOCATION.....	6	STORAGE BATTERY.....	23
OPERATING	9	AIR CLEANER.....	24
KEY.....	9	SPARK PLUG.....	24
IGNITION SWITCH.....	9	ENGINE OIL.....	25
DASHBOARD.....	10	CARBURETOR.....	27
LEFT、 RIGHT HANDLEBAR.....	10	DRIVE CHAIN.....	27
FUEL TANK CAP.....	12	BRAKES.....	29
FUEL COCK.....	12	REAR BRAKE LIGHT SWITCH.....	30
REAR SHOCK ABSORDER.....	14	TYRE.....	30
FUEL & ENGINE OIL RECOMMENDATION- S.....	15	LIGHT CHANGING.....	32
BREAK-IN FOR A NEW MOTERCYCLE.....	15	FUSE.....	32
INSPECTION BEFORE RIDING.....	17	INSPECTION AND MAINTENANCE.....	33
RIDING ESSENTIALS.....	18	CHEANING.....	34
STARTING THE ENGINE.....	18	STORAGE GUIDE.....	35
RIDING.....	20	SPECIFICATIONS.....	38
STOPPING AND PARKING.....	20		
INSPECTION AND MAINTENANCE.....	22		

CONSUMER INFORMATION AND BREAK-IN INFORMATION FOR YOUR MOTORCYCLE

The first 1600 km is the most important in the life of your motorcycle. Proper break-in operation during this time will ensure maximum life and performance of your new motorcycle. Zhenhua motorcycle parts are made of high quality materials, and machined precisely, so the right way of break-in can ensure every part being absolutely smooth and precise. It is most important that you should avoid operating the engine in the manner which could cause the engine parts to excessive heat such as running at very high speed for a long time.

Please refer to “break-in” section for specific break-in recommendation.

WARNING/CAUTION/NOTE

Please read this manual and follow its instruction carefully. To emphasize special informa-

tion, the words “WARNING”, “CAUTION” and “NOTE” carry special meaning and should be carefully reviewed.

WARNING!

The personal safety of the rider may be involved; disregarding this information could result in casualty to the rider.

CAUTION:

These instructions point out special service procedures or precautions that must be followed to avoid damaging the machine.

NOTE:

This provides special information to make maintenance easier or important instructions clearer.

CONSUMER INFORMATION PRECAUTIONS ABOUT ADDING ACCESSORIES AND PREPARATION BEFORE RIDING

You may buy all kinds of accessories to add your Zhenhua motorcycle, but unnecessary and unsuitable accessories would invite trouble for your riding. It is impossible for Zhenhua to check the quality of every accessory in the market, but our service station can supply you with high quality accessories and can equip properly for you.

Please choose and add accessories carefully and you should comply with the following instruction:

(1) When adding the extra weight accessory and the accessory in the direction towards wind, The adding position should be lower; it should approach the center of gravity and the body of motorcycle. To make sure it added fastened, the brackets and accessories should be carefully checked

in; unfastened equipment will cause the diversion from the center of the gravity and inviting unnecessary trouble.

(2) Checking the off-ground height of accessory and the angle, the improper adding will make the two aspects unsafe, also the accessory adding should not hinder parking, diverting and other manipulating.

(3) To avoid the unbalance problems, the accessory should not add on the steering wheel and the front fork.

(4) Some accessory adding may cause the seat of the driver diverting from the original position, this doesn't only restrict the range of driver's action, but limit his skill of operating as well.

(5) The extra electric fitting may weight the original electric system, on some over-weighted conditions, the accessory may be destroyed or the power may be cut off.

When adding the accessories, it should fasten to the body of the motorcycle; the improper adding would invite trouble for your driving and manipulating. The size of the accessory would affect the air-resistance and the manipulating. Please make sure the two side's balance and the accessories fasten.

SAFE RIDING RULES

Motorcycle riding is great fun and an exciting sport. Motorcycle riding also requires that some extra precautions be taken to ensure the safety of the rider.

The driver should comply with the following rules:

WEAR A HELMET

Motorcycle safety equipment starts with a good quality helmet. One of the most serious injuries that can happen is a head injury. ALWAYS wear a properly approved helmet. You should also wear suitable eye protection.

DRESS

The slack and curious clothing will make you uncomfortable and unsafe, so please choose the good quality and tight clothing.

REVIEW THE OWNERS MANUAL

Review thoroughly this owner's manual to familiarize your motorcycle construction and basic characteristics, then make a pre-ride inspection as per "inspection before riding" and perform any needed adjustments making the parts in best condition to ensure the safety of the rider.

FAMILIARIZE YOURSELF WITH THE MOTORCYCLE

Your riding skill and your mechanical knowledge form the foundation for the safe riding practice. We suggest that you practise riding your motorcycle in a non-traffic situation without obstacles until you are thoroughly familiar with your

machine.

KNOW YOUR OWN SCOPE OF SKILL

The riding should be always controlled in the scope of your riding skill, never try the risky riding.

PAY ATTENTION TO SOME SPECIAL CONDITIONS

Pay more attention during the bad weather days. Riding on bad weather days, especially wet ones, requires extra caution. Breaking distance double on a rainy day. You should ride the motorcycle slowly and keep a sufficient brake distance.

Take extreme caution at railway crossings and on metal gratings and bridges. Whenever in doubt about road conditions, slow down!

PRECAUTIONS ABOUT THE RIDING ACCIDENT

Many motorcycle accidents happen during motorcycle turning or other vehicle turning in front

of motorcycle, therefore, it is best to wear bright or reflective clothing and take care while turning. You should turn on the front and rear light to remind other drivers. Never drive your motorcycle into other driver's blind spot.

MODIFICATION

It is dangerous and illegal to modify the equipment or remove the parts from the original equipment, so all the equipment should in comply with the specification.

SERIAL NUMBER LOCATION

The frame and engine serial numbers are used to register the motorcycle; it is also useful for the Zhenhua maintenance station.

The frame number ① is stamped on the steering head tube. The nameplate ② is reverted on the surface of steering head tube.

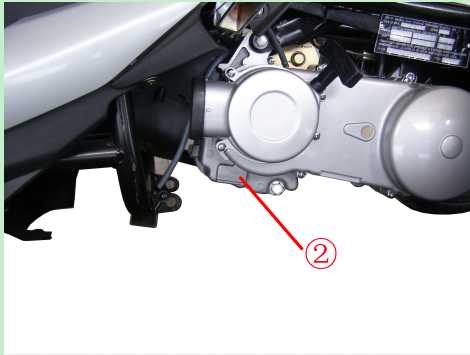
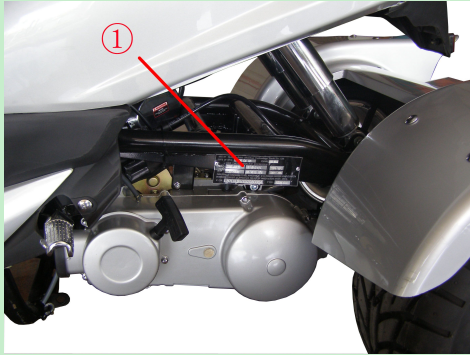

Please write down the numbers here for reference:

Frame NO.:

Engine NO.:

PARTS LOCATION

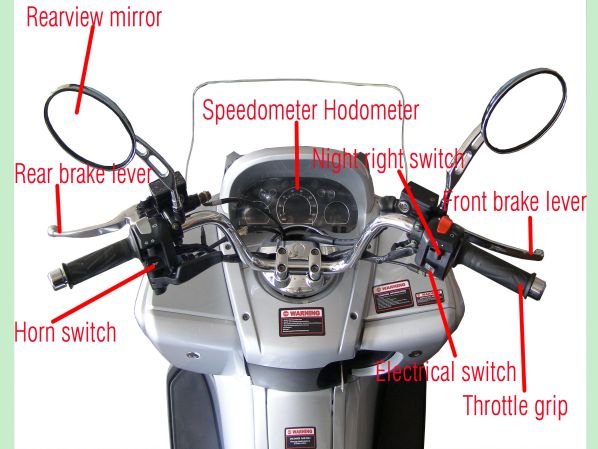

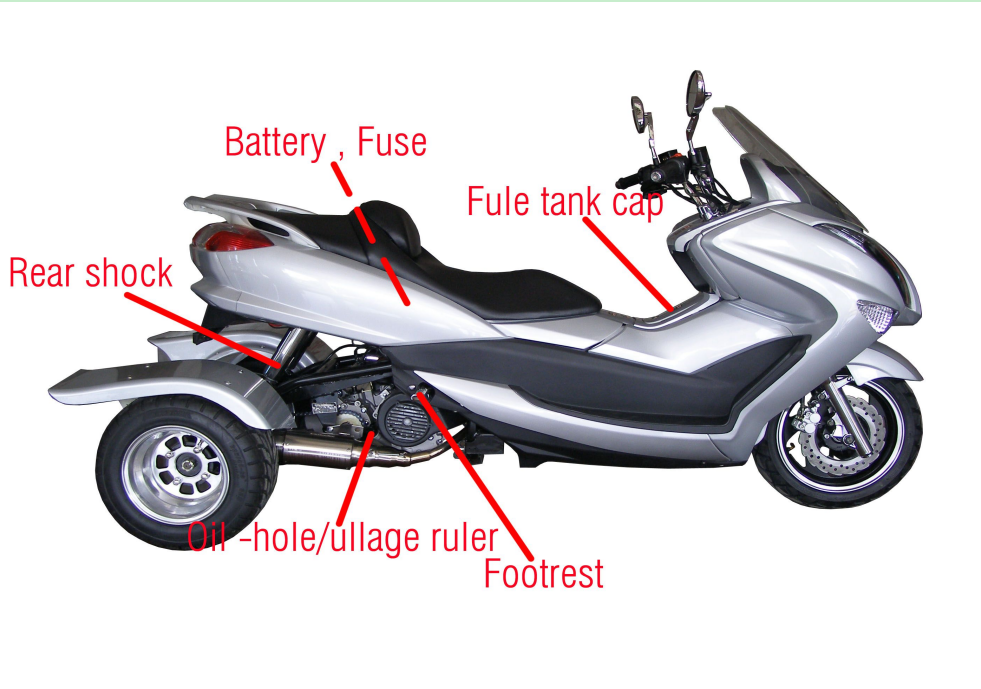

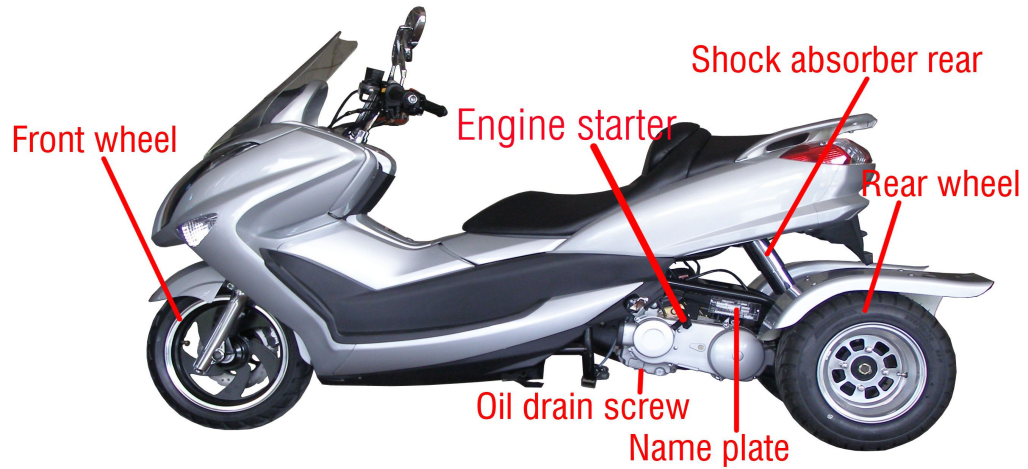

STEERING SYSTEM

KEY there are two keys to the motorcycle. The keys can control sparking switch, steering- lock, cap lock and helmet-pole lock.

SPARK SWITCH

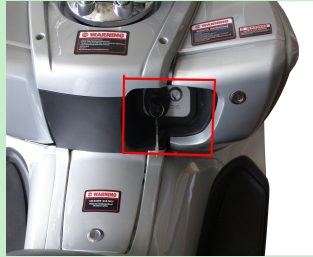
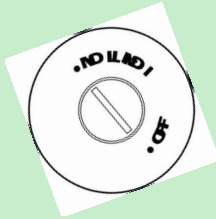

There are two positions:

“OFF” position

When all the electricity was cut off and the engine could not be opened up, the key can be pulled out.

“IGNITION” position

When all the electricity working, you may ignite at any time, the key can not be pulled out

FUEL TANK CAP

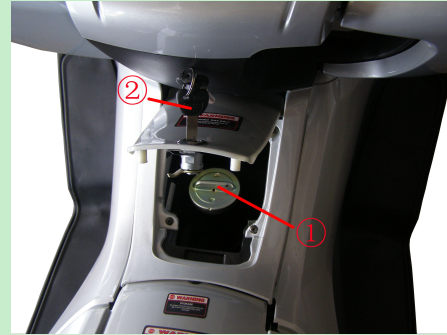

(1)FUEL TANK CAP

(2)IGNITION KEY

When you want to open the cap, insert the key into the hole on the cap and turn on clockwise, the cap can be opened.

The fuel tank capacity is 4.9 L, in which the reserve capacity is 1.6 L.

WARNING!

Do not overfill the fuel tank to prevent the fire caused by fuel overflowing to hot engine.

Never refuel near an open fire.

INSTRUMENT PANEL



Speedometer ①

The speedometer is used to show how many

kilometers per hour the running speed is

Odometer ②

The odometer is used to show how many kilometers the motorcycle has driven.



Neutral indicator ③

When the transmission is in the neutral, the indicator is lighted up. In other gears, the indicator will be extinguished.

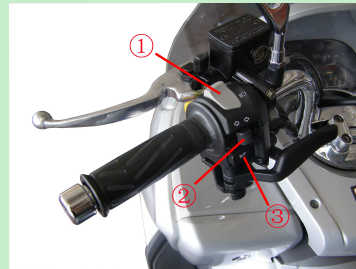
LEFT HANDLEBAR SYSTEM



VARIABLE SWITCH ①

When you riding at night, push the button on “” position, on condition that the button of right light is on “” position, the high beam and the night beam can be lighted up. Put the button on “” position, the dipped headlight can be lighted up. If these lights are unnecessary, push the button of right light on “•” position.

LEFT-RIGHT TURNING SIGNAL BUTTON

Turn the “←” button left , the left signal can be lighted up . Turn the “→” button right, the right signal can be lighted up . The indicator on the dashboard can also be lighted up. If you want to turn down the signal, press the button down.

WARNING

**SENT THE SIGNAL BEFORE SHIF-
TING ROAD AND TURN DOWN THE
SIGNAL IF FINISHED**



HORN BUTTON③ “”

Press down the button, the horn blares.

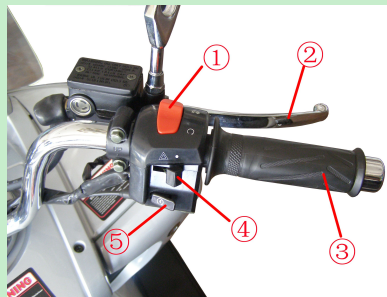
RIGHT STEERING SYSTEM



ENGINE STOP SWITCH①

Press the “” the electricity can be connected and the engine can work. It is of a emergency stop switch. If the button is on “” position, the engine can not work, the starting electricity is totally cut off

FRONT BRAKE LEVER②

Pulling back the lever will break the front wheel and the rear brake light will be lighted up.

THROTTLE GRIP③

The throttle grip is used to control the engine speed. Twist the throttle grip toward yourself to increase the engine speed. Turn it away from yourself to decrease the engine speed. Turn it away from yourself to decrease the engine speed. Turn it away from yourself to decrease the engine speed.

LIGHT BUTTON④

“☀️” : in this position, the headlights, backlights, parking lights and dashboard lights are lighted up.

“🚗” : in this position, the backlights, parking lights and dashboard lights are lighted up.

“ • ” : in this position, the headlights, backlights, parking lights and dashboard lights are powered off.

ENGINE BUTTON⑤“ ⚡️ ”

Press this button can power on the electricity of motor. If the button of the motor is in the position

of “⊗” , the motor can not be powered on, the gear must in neutral before the motor is powered on.

CAUTIONS

TOO MUCH DISCHARGE WILL MAKE THE CIRCUIT AND MOTOR TOO HOT, POWER ON THE MOTOR FOR NO MORE THAN FIVE SECOND ONCE A TIME. AFTER SEVERAL FAILS OF OPERATING, YOU SHOULD CHECK THE FUELING SYSTEM AND STARTING CIRCUIT.

FUEL COCK

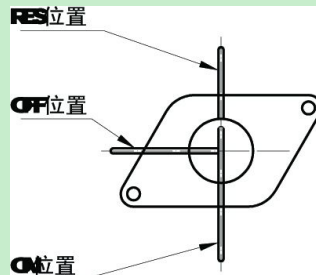

This type of motorcycle is equipped with manual acting fuel cock. There are three positions: “ON”, “RES” and “OFF”.

“ON” position

Normal position while operating the motorcycle when the fuel level in carburetor drops, the gasoline flows through the fuel cock into the carburetor.

“RES” position

If the fuel level in the fuel tank is too low, turn the cock to the “RES” position to use the 1.6 L reserve fuel.

“OFF” position

If the engine stops for a few minutes, put the fuel lever to “OFF” position.

WARNING!

To make sure the fuel tank button is on “OFF” position when turn off the engine.

CAUTION:

After setting fuel cock to “RES” position, please fill fuel at the nearest fuel station immediately. After filling, please note that fuel cock must be set “ON” position.

REAR SHOCK ABSORBER

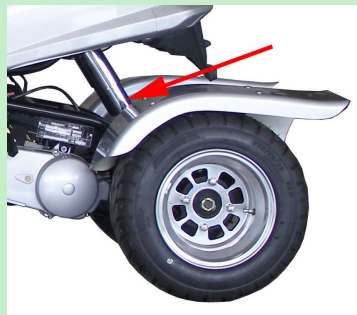

There is shock absorber in the front the rear wheel; it is designed according to rider’s requirements, loading, road condition and other factors. It is factory set and no adjustment is needed.

TAIL HOOK

To haul the baggage car or other small car.



REVERSING GEAR DEVICE

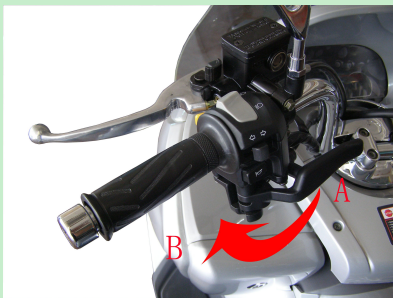

Pull from A to B for reversing gear.

FUEL AND ENGINE OIL RECOMMENDATION

FUEL

Please use unleaded [GB17930-1999] petrol with a octane number of 91 or high. Using the unleaded high quality oil can prolong the life of your motorcycle and can also contribute to environmental protection.

ENGINE OIL

The engine oil used in this motorcycle conforms to Chinese National Standards GB11121-95 and American National Standards SAEJ183E80. Please use good quality 10W/40QE engine oil. Zhenhua special engine oil, band four-stroke 15w/40 engine oil, is strongly recommended to use. Mixed oil with different brand is unallowable.

Choose the different engine oil according to the various area and climate.

The following items are the different engine oil use in sphere of application.

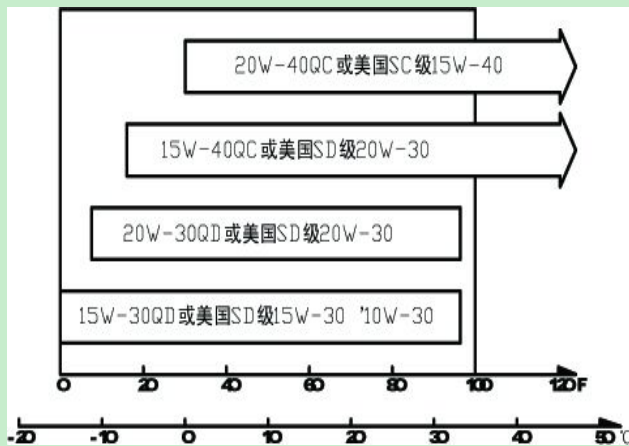

BREAK-IN FOR A NEW MOTORCYCLE

The forward explains how important the proper running-in is to achieve maximum life and performance of your new motorcycle. The following

guidelines explain proper running-in procedures.

The following table shows the maximum recommended throttle opening during the break-in period:

Initial 800 km	less than 1/2
To 1600km	less than 2/3

VARY THE ENGINE SPEED

The engine speed should be varied and not hold at a constant speed. This allows the parts to be “loaded” with pressure, and then unloaded, allowing the parts to cool. This aids the mating process of the parts.

It is essential that some stress be placed on the engine components during bread-in to ensure this mating process. Do not, though, apply excessive load on the engine.

AVOID CONSTANT LOW SPEED

Operating the engine at constant low speed (light load) for a long time can cause parts to graze and not fit close to each other. Allow the engine to accelerate freely through the gears, without exceeding the recommended maximum limits. Do not, however, use full throttle for the first 1600 km.

ALLOW THE ENGINE OIL TO CIRCULATE BEFORE RIDING

Allow sufficient idling time after warm or cold engine start up before applying load or reviving the engine. This allows time for the lubricating oil to reach all critical engine components.

PERFORM THE NECESSARY PERIODIC MAINTENANCE

The initial 1000 km service is the most important to your motorcycle. During break-in all of the engine components will fit close to each other

sufficiently. All adjustments will be restored, all fasteners will be tightened, and the dirty oil will be replaced.

Timely service during the 1000km service will ensure optimum service life and the best performance of the engine.

WARNING

Maintenance for 1000km should be according to the “maintenance planning” in the specification. Pay more attention to the “NOTE”& “WARNING”.

INSPECTION BEFORE RIDING

Before riding the motorcycle, be sure to check the following items. Never ignore the importance of these checks. Perform all of them before riding the machine.

WHAT TO CHECK	IMPORTANT ITEMS
Steering	1) Smoothness 2) No restriction of movement. 3) No play or looseness
Brakes	1) the fluid level in brake fluid reservoir should be higher than the “LOWER” lever limit. 2) Brake shoes to be within the wear limit.3) No dragging (sponge status)
Tires	1) proper pressure. 2) Adequate tread depth. 3) No cracks or cuts on the tire surface.
Fuel reservation	Enough fuel for the planned distance of operation.
light	Operating all the lights ——front light, rear light, brake light, light of dashboard,
indicator	
Horn button	The function is in normal
Engine oil	proper oil level
throttle	1) Correct play in the throttle cable 2) Smooth operation
Drive chain	1) Proper tightness. 2) Proper lubrication.3) degree of wear
Assemble tautness	Fasten the lax parts

RIDING ESSENTIALS

WARNING

1: if you ride this motorcycle for the first time, we suggest that you practise riding your motorcycle in a non-traffic situation without obstacles until you are thoroughly familiar with your machine.

2: Do not drive your machine with one hand. Do not drive your without hand in any conditions.

3: Do not brake hardly while turning, slow down while turning.

4: You should ride the motorcycle slowly and keep a sufficient brake distance in rainy and smooth road.

5: Observe the traffic regulation and limit the speed.

STARTING THE ENGINE

WARNING

Never start the engine in the narrow position to avoiding danger

When the engine is “COLD”, the procedure is as follow:

- 1) Turn the fuel cock to “ON” position
- 2) Insert the key into the lock of electric switch and turn to “ON” position
- 3) The throttle opening should be less than 1/8, press the kick starter lever. As soon as the engine started, release the kick starter lever quickly.

NOTES:

Do not race your engine when you are not riding. A long time race will make your engine too hot and destroy the interior parts.

WARNING:

Never start the motor for five seconds one time, because too much discharge will make the electricity and starting motor too hot. Try several times; check the oil supply system and electricity starting system if still fails.

NOTES:

In some cold area, push the electric button on “OFF” position before starting the machine, closed down the chock valve, open the throttle then press the starting lever for several times to make the engine easy to start.

WARNING:

Do not try to start the engine in the staff room for the poisonous of carbon monoxide, stop the engine while there is no person watching it.

RIDING:

NOTES:

Preview the related riding knowledge before riding.

STOPPING AND PARKING

- 1) Twist the throttle grip away from yourself to close the throttle completely.
- 2) Use the front and rear brakes evenly and at the same time.

WARNING

When your motorcycle is speeding up, keep a long distant before braking. In order to have enough time to brake, you should consider the distant between you and vehicles.

The drivers with no experience are used to brake by the rear brake; this will increase the abrasion of the

rear brake system.

It is dangerous to stop your motorcycle by only using the front or rear brake, this method will make your motorcycle out of control for the skidding. Take more care and use the brake system slightly in the rainy and smooth road. To brake sharply in the rugged and smooth road will make your out of control.

Turn the key to “off”

Lock the steering to ensure the safety

Pull out the key.

INSPECTION AND MAINTENANCE

The following chart indicated the intervals between periodic services in kilometers and months. As the end of each interval, be sure to inspect, check, lubricate and service as instructed. If your motorcycle is used under high stress condition such

as continuous full throttle operation, or is operated in a dusty climate, certain service should be performed more often to insure reliability of the machine as explained in the maintenance section. Your Zhenhua dealer can provide you with further guidelines. Steering components, suspension and wheel components are key items and require very special and careful servicing. For maximum safety we suggest that you have these items inspected and serviced by your authorized Zhenhua dealer or qualified service mechanic.

WARNING:

The periodic checking and maintenance to your motorcycle is very necessary and important to ensure your safety and prolong your motorcycle service life.

NOTES:

You will change one or several parts in the period of checking and maintenance. We suggest that you use the authorized Zhenhua parts. Mechanic experts or experienced repairman, we suggest that you have the item with*serviced by the authorized and qualified service mechanic. For the item without* you may have it inspected or repaired by yourself.

INTENANCE CHART

Item	Period	1000	3000	8000
	Month	5	20	40
*Exhaust pipe bolts, cylinder head nuts		T	T	T
*Crankcase drive chain		CH	CH	CH
Air cleaner		---	C	C
*Valve clearance		Check every 12000 km		
Spark plug		---	C	R
*Fuel line		---	C	R
		*Replace every 4 years		
Engine oil		R	R	R
Oil filter		R	---	R
Carburetor		CH	CH	CH
Drive chain		CH	CH	CH
		Apply oil every 1000 km		
*Brakes		CH	CH	CH
Tires		---	CH	CH
*Steering		CH	---	CH
*Front fork		---	---	CH
*Rear suspension		---	---	CH
*Chassis bolts and nut		T	T	T

TOOL

There is a set of tool with the motorcycle for your inspection

ACCUMULATOR

Open the seat, the accumulator can be seeing.



NOTES

The voltage of accumulator is 12v without liquid inspection and watering.

NOTES

1) In order to avoid dangerous, do not open the

sealed cap at any time.

2) The condition of electrification can be inspected by the voltmeter.

(The normal voltage is more than 12.8v)

CAUTIONS:

Although the accumulator is totally sealed, the improper operation will invite trouble.

Please observe the following items:

- 1) Fasten the accumulator, never make it loosen or make the cathode and anode opposite to each other.
- 2) Never place it in the high-temperature or smoke and flame location.
- 3) If your eyes or skin is stained with vitriol, clean it with water or go to doctor as soon as possible.

THE METHOD OF CHARGING WITH SEALED ACCUMULATOR FOR YOUR MOTORCYCLE:

- 1) To energize after half a year's storage.
- 2) To energize as the following method.

Constant-voltage charging by current limiting, the charging voltage is between 13.8v and 14.5v, the current limiting is between 1.5A and 2.5A, the charging time is between 9 and 12 hours.

NOTES

The red line is connecting anode and the black line is connecting cathode. The opposite connecting will destroy the charging system and the accumulator.

AIR CLEANER

The air cleaner filter used in this motorcycle is a polyurethane foam filter. If the filter has become clogged with dust, intake resistance will increase with a resultant decrease in power output and increase in fuel consumption due to richer mixture. Clean the air cleaner filter periodically.

CAUTION:

If driving under dusty conditions, the filter must be cleaned and replaced more frequently.

CAUTION:

Never operate the engine without the air cleaner in position. Operating the engine without the air cleaner will increase engine wear. Always be sure that the air cleaner is in excellent operational condition at all times. The life of the engine depends largely on this component.

SPARK PLUG

We suggest you can use the qualified parts-

NGK C7HSA

1) Pull out the spark cap

2) Remove the spark plug with a plug wrench and clean all the dusty on the bottom.

Remove the carbon deposits from the spark plug with a small wire brush or a spark plug cleaning machine. Readjust the spark plug gap to 0.6-0.8 mm by using a spark plug gap thickness gauge if it is necessary. The spark plug should be replaced periodically.

The procedure of installing spark plug is opposite to take down it, please make sure that the washer is connecting to the spark plug.

NOTES:

1) Do not make the spark plug too fastened for fear of destroying the screw thread. Never make the impurities come into the engine through spark plug hole when taking down the spark plug.

2) The spark plug in this motorcycle is elaborate selected and can meet most working. If the color of spark plug is quite different from the standard plug, you'd better contact with the Zhenhua dealer. For the improper spark plug will effect the engine's working.

3) Use the spark plug specified on the VECI label or will invite trouble for your operating, so you'd better contact with the Zhenhua dealer before choosing it.

ENGINE OIL

Using a good quality engine oil and periodical replacement of engine oil will extend your engine's life. Check engine oil level daily and replace engine oil periodically are two most important tasks to be carried out for maintenance items.

CHECKING ENGINE OIL LEVEL

Checking the oil level after the engine stopped working for several minutes, the motorcycle should

be placed on the plain ground. Insert the dipstick ① until it seats, but not screw it in. the oil should be between the upper lever mark ② and the lower lever mark ③. If necessary, add the recommended oil until it reaches the upper level mark, do not overfill.

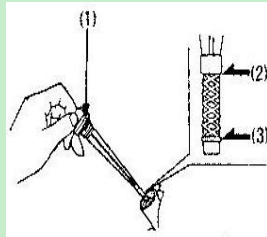
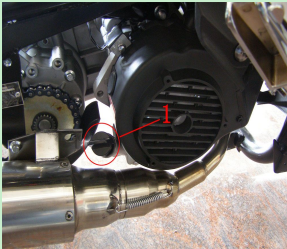

REPLACING ENGINE OIL

The engine oil replacement should be carried out when the engine is warm, when replacing the engine oil, support your motorcycle with side stand to facilitate draining the oil fully. The procedure is as follow shown:

1) Stand your motorcycle with side stand. Put a drain pan under the engine.

2) Unscrew and remove the oil drain bolt ① under the engine to drain the dirt oil.

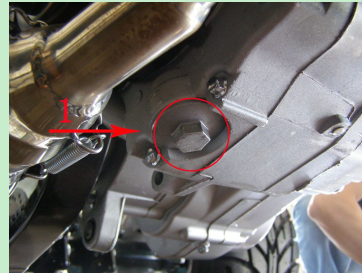

WARNING

To avoid unnecessary hurt when the fuel and engine oil was heated.

3) stamp the kick starter lever for several times to drain the remaining oil.

4) Replace the used oil filtering net with a new one, check whether the spring and sealing washer are

well installed.

5) Pour 0.8L recommended oil into the engine. Start the engine, let it run at idle speed for 2-3 minutes, shut off the engine and wait for a minute, check whether the oil is at upper level mark. If the oil level is below the upper level mark, add the oil until it reaches the upper level mark.

NOTES:

1) Check oil filler and oil drain bolt carefully to avoid dripping.

2) Engine oil should be replaced frequently when riding in dusty area.

3) Please use the oil which we recommend in the “**FUEL AND ENGINE OIL**” item.

CARBURETOR:

The stable function of carbureting is the basic request for a engine, the carburetor is set for the best calibration in the factory. Do not attempt to alter its

setting. There are two items of adjustment, however, under your care: the idle speed and the gap of throttle cable.

DRIVE CHAIN

We suggest that you’d better entrust Zhenghua dealer with replacement of drive chain when the chain was damaged.

WARNING!

To ensure the maximum safety, the inspection and adjustment of drive chain should be carried out before riding.

When performing the periodical check, the following state of drive chain should be checked.

- 1) Loose pins
- 2) Dry or rusty chain links or twisted or bonded links
- 3) Damaged sprocket
- 4) twisted or bonded links
- 5) excessive damage
- 6) incorrect adjusting chain

If the above troubles found, the sprocket may be

considered to cause the damage of the chain.

Therefore the following check of the sprocket is necessary.1) Excessive wore teeth 2) damage or frangible teeth 3) Loose pins

drive chain cleaning
and oiling

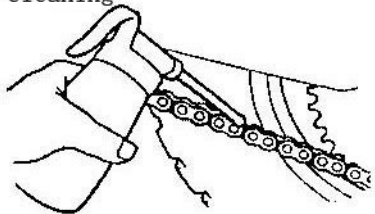

A dirty drive chain may not only accelerate the chain wear, but also damage the sprocket. Therefore after cleaning it with clean deterging. Smear the drive chain with special chain oil or engine oil.

drive chain adjustment

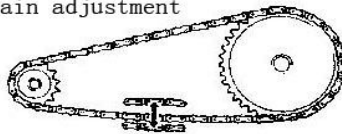

20~30mm

The drive chain should be adjusted irregularly as per the riding condition to maintain it in normal status.

WARNING!

Excessive chain slack could cause the chain to come off the sprockets and result in an accident or serious engine damage. Please check and adjust the drive chain constantly.

WARNING!

The hot silencer may hurt you, it will hot enough to hurt you even the engine was closed. In order to avoid scald, please inspect your drive chain after the silencer was cooled down.

NOTE:

Check the front and rear sprocket for wear when replacing the drive chain, replace the sprocket if necessary.

BRAKES

This motorcycle has hydraulic disc front and rear brake. Brakes are items of personal safety and should be properly adjusted. We suggest that you should entrust Zhenhua dealer with this check.

FRONT BRAKE**BRAKE FLUID****WARNING!**

The brake fluid is poisonous, if swallowed, forced to spit it. Avoid contact with skin or eyes. In case of contact, flush thoroughly with water and call a doctor if your eyes were exposed.

Please check the fluid lever whether it is upward the “LOWER” level mark

The brake fluid should be added to the reservoir whenever the fluid level begins to reach the “LOWER” level mark please make the fluid upwards the “HIGHER” mark

CAUTION:

Do not use the remained brake fluid from a unsealed container, and the brake fluid remained in the last repairing, because the used brake fluid may absorb the water from the air influencing the performance of brake. Only DOT3 brake fluid can be

used. Never make the brake fluid splash on the surface of painting and rubber.

NOTE:

Checking whether the pipe is in poor condition and whether there is enough fluid.

WARNING:

If the brake system or brake pads have to be repaired, we suggest that these repairs should be performed by your Zhenhua dealer. Zhenhua dealer knows your motorcycle better and is dedicated to your complete satisfaction.

CAUTION:

The high pressure brake is used by disc brake system. To ensure the safety, the replacement interval should not be more than that stipulated in “MAINTENANCE SCHEDULE” of this manual

When performing the periodical check, the following state of brake system should be checked.

- 1) Dripping or not
- 2) Crack tube or not
- 3) Keep the certain recovery
- 4) Wore brake pads

WARNING:

When the new brake pads begin to be used, don't ride your motorcycle immediately after the replacement. Apply the brake, release it. Repeat this procedures several times and allow the brake fluid to circulate normally.

REAR BRAKE

Similar method as front brake

TYRES

Check your tires for both wear and inflation pressure to ensure the riding safety before riding and when performing the periodic inspection.

NOTE:

This motorcycle is traffic-motorcycle. Riding on the hill road, desert, rugged road and rainy road will invite troubles. Disobeying the stipulation will cause serious dangerous.

TIRE PRESSURE

Improper tire pressure may not only hastens tire wear but also serious affects the stability of the motorcycle, over inflation may result in the reduction of the contract area between the tires and ground, which may cause side slip of motorcycle and loss of the control to the vehicle. Therefore tire pressure should be within specified range. Adjust the air pressure correctly when the tires are cold.

Cold inflation tire pressure:

	Front tire:	Rear tire:
tire pressure	220. 6KPa	206. 9KPa

Tire Specifications	130/60-13	205/50-10
	M/C	

Check your tire for both wear and inflation pressure to ensure the riding safety, make sure that there are no mark cut, nail and other sharp material inserting in your tire. If there is any wear status, please the Zhenhua dealer.

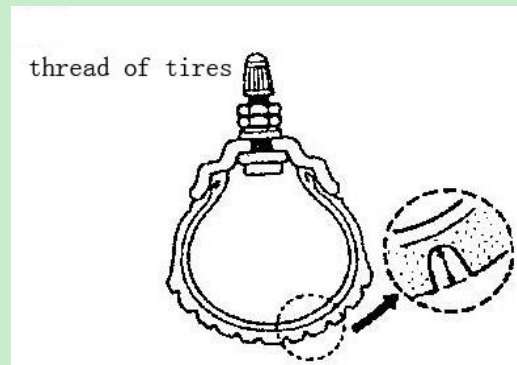
THREAD OF TIRES

It is dangerous to use the wear tires; it will

affect the traction, stability, steering and operating system. A new front tire should be replaced when the depth of thread is decreased below 1.6 mm.

A new rear tire should be replaced when the depth of thread is decreased below 2 mm.

WARNING:

The standard of your tires is as follows:

Front tire: 130/60-13 M/C Rear tire: 205/50-10

Improper tires will cause danger, so we strongly recommend you choose the tire from Zhenhua dealer.

Tire inflation pressure and the general tire condition are extremely important to the proper performance and a safety of the vehicle. Check your tires frequently for both wear and inflation pressure.

Replace the tire as per following stipulation.

RENEWAL OF LIGHT:

When changing a burned bulb, the same power bulb should be meeting. If use the improper bulb, the

whole electrical appliance may be destroyed and the burn will burn out. “The specification “and “electrical appliance” will give you more information for your consideration.

WARNING:

When the bulb is very hot in “ON” position, this condition will last for a short time after the button was turn off. So the bulb should be cooled down before operating.

NOTE:

Turn the igniting on “OFF” position when changing the bulb.

Check in again after finishing the bulb changing to make sure the new bulb can work well.

FUSE:

There is a fuse box beside the storage cell. The entire electrical appliance is protected by a fuse. Please check the fuse first when your motorcycle is dead. If the fuse has burned out, that may suggest the electrical appliance is overloaded or short-circuit. Please trust Zhenhua dealer for your repairing.

NOTE:

Turn the igniting button on “OFF” position before changing or inspecting fuse.

WARNING!

Do not use other standard fuse, which may destroy your engine and light.

TROUBLE-SHOOTING

If you can't start your engine, please check in as the follows steps

- 1) There is not enough fuel in the tank
- 2) Whether the fuel has flows into carburetor from

fuel system.

- 3) If the last step has been verified, please check the igniting system.

WARNING:

Do not make the fuel flow all ground, it should be put into containers. Keep the fuel off the hot engine and exhausting pipe. Keep away from fire or fire source or hot source while performing the test.

- 1) Remove the spark plug and connect high-tension lines.
- 2) Fasten the spark plug on the motorcycle. Turn the ignition switch on “ON” position and press down the button to start it. If the ignition works well, there will be sparks between spark plug play. If there is no spark please contact Zhenhua authority repair station.

WARNING!

Don't let the spark plug to be near spark plug to be near spark plug opening aperture in cylinder head, because the fuel vapor in cylinder can ignite causing fire.

For reducing the possibility of electronic breakdown. Metal parts of spark plug should be close to the metal parts of frame without paint.

For preventing from the possibility of electronic breakdown. People should avoid processing this checking, who has heart disease or heart pacemaker.

ENGINE IMPETUS IS NOT SUFFICIENT

- 1: check for fuel supply system of fuel tank.
- 2: check for ignition timing of ignition system.
- 3: check for engine idle speed.

CAUTION:

Before servicing, you are strongly recommended to contact Zhenghua authorized service center. If your motorcycle is valid in guarantee period, servicing by yourself may affect your advantage of guarantee.

CLEANING:

To protect the surface of painting, you should clean your motorcycle periodically. Check for the wear parts and the lacking of engine oil.

NOTE:

High pressure current may damage the parts of your motorcycle.

To avoid spraying the follows parts with high pressure current.

Ignition switch instrument carburetor drive chain entrance of silencer bottom of fuel tank switch of steering bar seat bottom

1) Spraying your motorcycle with clean water after finishing cleaning. Some remains of detergent may eroded the alloy parts.

NOTE:

Clean the plastics with soft cloth clean the dirty place several with clean water.

2) Start the engine and make it run for several minutes after drying the motorcycle.

3) Before start the engine again, try the brakes several times until the normal function can be shown.

WARNING:

You'd better consider the distance for braking to avoid danger after cleaning.

4) Add the lubricating oil to the drive chain after cleaning and drying.

ALUMINUM TIRE MAINTENANCE:

The corrosion is caused when the aluminum tire

gets to rocky and mud road. You'd better clean and dry it with soft cloth.

NOTE:

To avoid the unnecessary scar, never use the abrasive detergent and polishing clean your tire.

STORAGE GUIDE

Extended storage, such as for winter, requires that you take certain steps to reduce the affects of deterioration from non-use of the motorcycle. In addition necessary repairs should be made before storing the motorcycle; otherwise these repairs may be forgotten by the time the motorcycle is removed from storage.

STORAGE

- 1: change engine oil.
- 2: drain the fuel tank and carburetor into a petrol container. Spray the inside of the fuel tank with aerosol rest-inhibiting oil. Reinstall the fuel filling cap.

CAUTION:

If storage will last more than half month, carburetor draining is very important to assure proper performance after storage.

WARNING!

Petrol is extremely flammable and is explosive under certain condition. Refuel in a well-ventilated area with the engine stopped. Do not smoke or allow flames or sparks in the area where the engine is refueled or where petrol is stored.

- 3: perform the following antirust procedures in

cylinder inside:

Remove the spark plug cover, fix it to near plastic parts with rubberize fabric or cord, let it separated from the spark plug.

Poor a tablespoon (15-20cc) of clean engine oil into the cylinder, then cover the spark plug hole with a cloth.

Operate the kick starter several times to distribute the oil.

Reinstall the spark plug and spark plug cover.

4: discharge the storage cell and putting in the place without freezing and direct sunlight. Charge it one time per half year.

5: wash and dry the motorcycle. Wax all painted surfaces.

6: lubricate the drive chain.

7: inflate the tires to their recommended pressure.

Place the motorcycle on blocks to raise both tires off

the ground.

REMOVAL FROM STORAGE

1: Uncover and clean the motorcycle. If storage has lasted more than 4 months, replace the engine oil.

2: charge the storage cell if necessary then reinstalls it on the original position.

3: drain the nebulous anti-rusting oil remained in fuel reservoir. Fill the fuel tank with fresh petrol.

4: perform all pre-ride inspection checks (refer to related contents).

Before restoring the normal riding, test ride the motorcycle in a safe riding area from traffic if no trouble found, you can restore the normal riding.

DIMENSIONS & SPECIFICATIONS:

Length.....	2250mm
Width.....	1020mm
Height.....	1320mm
Wheel base.....	1720mm
Ground clearance.....	110mm
Weight.....	170kg
Maximum load.....	150kg

ENGINE

Model.....	1P57QMJ
Type.....	single cylinder four stroke forced-air cooled
Bore.....	57.4mm
Stroke.....	57.8mm
Piston displacement.....	149.6ml
Compression ratio.....	9:2:1
Carburetor.....	piston type
Air cleaner.....	polyurethane foam filter
Starter system.....	pull and electricity

Lubrication system...pressure and splash combined	
Max. speed.....	80km/h
Max oil consumption.....	3.2L/100km
Max power.....	6.2kw (7500r/min)
Standard power and rotation	6.0kw (7000r/min)
Max torque.....	8.2N.m (6500r/min)
Idling.....	1600r/min
... ..	0 . 8 L

· **This manual should be regarded as one permanent component of the motorcycle. Keep it well with the motorcycle when you resell or lend the motorcycle to other man. The proper operation and maintenance information that your motorcycle requires is outlined in this manual. You should become thoroughly familiar with the information presented in this operation manual before riding your motorcycle.**

· **All information, instructions, photographs and specifications contained in this manual are based on the latest product information available at the time of publication. Due to improvements or other changes, there may be some discrepancies in this manual. Zhenhua reserves the right to make changes at any time without notice.**

